

HZ-5000 Underground Cable Fault Detector

User Manual

Dear user:

Thank you for choosing HZ-5000 Underground Cable Fault Detector.

We hope that this instrument can make your work easier and more enjoyable, so that you can get the feeling of office automation in the test and analysis work.

Before using the instrument, please read this manual, and operate and maintain the instrument according to the manual to prolong its service life. "Just a light press, the test will be completed automatically" is the operating characteristics of this instrument.

If you are satisfied with this instrument, please tell your colleagues; if you are not satisfied with this instrument, please call (0312) 6775656 to tell you to serve you at all times-Baoding Huazheng Electric Manufacturing Co., Ltd., our company will definitely make you satisfied !

Contents

I.Overview.....	2
II.Features ofHZ-5000 Cable Fault Detector.....	2
III.Components and structural functions ofHZ-5000 cable fault detector.....	4
IV. Specifications.....	19
V. Parts and Accessories.....	20
VI. Check before use.....	20
VII. Ways of Pipe locating:.....	23
VIII. Procedures of Detection.....	41
IX.Common Pipe Detection Techniques.....	44
X.Anti Corrosion Coating Inspection.....	49
XI.Cable low resistance and broken line fault points.....	52

I.Overview

The HZ-5000 underground cable fault detector can accurately locate and measure the buried depth of underground pipelines, cables, and optical cables without excavation, and accurately find the location of the damaged point of the outer anti-corrosion layer of the underground pipeline and the fault point of the buried cable. The instrument integrates the most advanced technologies such as ultra-narrowband filter, Bluetooth wireless communication, GPS positioning, professional data analysis software automatic mapping, automatic generation of test reports, etc. It has super anti-interference ability, precise positioning and depth sounding, and is suitable for various underground The detection and inspection of metal pipelines, pipeline management and maintenance, municipal planning and construction, power supply and other departments are the necessary instruments for pipeline maintenance units.

II.Features of HZ-5000 Cable Fault Detector

1. Multiple Functions

- 1) Transmitter: three connection modes: inductive connection, direct connection and clamp connection; suitable for different occasions.
- 2) The receiver functions: detecting the position, path, depth and tube current of underground pipes and cables.
- 3) Left and right positioning arrows indicate the target pipeline position fast and accurately; front and rear arrows and dB value indicates the point and size of the coating damage.
- 4) Backlight suitable for urgent use in the nighttime.
- 5) Optional GPS geolocation with the automatic mapping of the pipelines.
- 6) Optional professional data analysis software with the automatic detection report.

7) Specific functions of HZ-5000 receiver: Used for locating faults (pipeline faults refer to damage of outer anticorrosion layer, cable faults refer to damage of outer sheath) and detecting insulation damage of underground pipelines.

8) Measuring the current of the pipeline and cable applied by the transmitter.

9) Multimeter function: measure the output voltage, line voltage, line current, impedance and power; Test the cable continuity and insulation quality before and after cable fault finding.

10) External induction clamp: suitable for testing the cable when they cannot be directly applied to the signal of the place.

2. High Location Accuracy

A variety of measurement modes for pipeline positioning (valley mode, peak mode, broad peak mode, peak arrow mode), can verify each other to ensure the accuracy of pipeline positioning.

1) Maximum value method: peak mode, broad peak mode and peak arrow mode are available to determine the horizontal component (H_x) or horizontal gradient (ΔH_x) changes, according to its maximum position to locate;

2) Minimum value method: use the valley mode by measuring the vertical component (H_z) changes according to its minimum position to locate.

3. Measuring the depth

A variety of methods can be used to verify each other.

- 1) double-level coil direct reading method;
- 2) single-level coil 80% method, 50% method;
- 3) 45 degrees method

4. Strong anti-interference ability

1) Many Observation Parameters: can measure horizontal component (H_x), vertical component (H_z) and horizontal gradient (ΔH_x).

2) Large transmission power: the transmitter output power reaches 10W and it could be continuously adjustable.

3) Multiple Working Frequency:

Transmitter frequency: 128Hz, 512Hz, 1KHz, 2KHz, 8KHz, 33KHz, 65KHz, 83KHz.

Receiver frequency: radio, 50Hz, 100Hz, 128Hz, 512Hz, 1KHz, 2KHz, 8KHz, 33KHz, 65KHz, 83KHz.

According to the target pipeline features (material, structure, depth, length, etc.) and the environment to select the appropriate operating frequency.

5. Easy Operation

1) Intuitive: use the graphical display to get the sustained and real-time display of various parameters in the detection process and signal strength.

2) Automatic: in the depth measurement, automatic change to the two-level antenna mode and automatic adjustment of the receiver sensitivity so that the measurement signal achieves the best result. The mode returns to the original one after the depth measurement.

6. Long continuous working time with the low cost

Both the transmitter and the receiver are equipped with a large capacity lithium battery pack. A fully recharge can last a whole working day outdoors. The recharging function has greatly reduced the detection costs.

7.AC and DC

Under normal circumstances, if the battery is sufficient, please use the instrument with built-in battery pack power supply. If the battery power is low, and the detection task is not completed, you can use the power adapter to continue the detection without having to recharge the battery.

III.Components and structural functions ofHZ-5000 cable fault detector

1. Receiver :



The receiver is used for the measurement of underground pipelines, cable positioning, buried depth of underground pipelines, and tube current measurements. A variety of frequency and mode of operation to meet a variety of environments and a variety of pipeline detection needs.

1.1 Functions:

Turn on/off (1)

Press the key to start the boot or to shut down. When the receiver is turned on, the receiver automatically shuts down if no function key is pressed during the set auto power off time. If any function key is pressed, the receiver will reset the shutdown time.

fbutton(2)

Frequency selection key: according to the frequency of the transmitter to select the corresponding detection frequency, selectable frequency including radio, 50Hz、100Hz、128Hz、512Hz、1KHz、2KHz、8KHz、33KHz、65KHz、83KHz.



Peak Mode

Valley Mode



Wide Mode

Peak Arrow

90dB



External Signal

Mode(3)



The mode key is used to select the receiver's operating mode for precise positioning of the pipeline. The positioning process is usually measured by the peak method.

Including:

Valley mode

Peak mode

Wide mode

Peak arrow mode

Power mode: 50Hz power cable can be detected

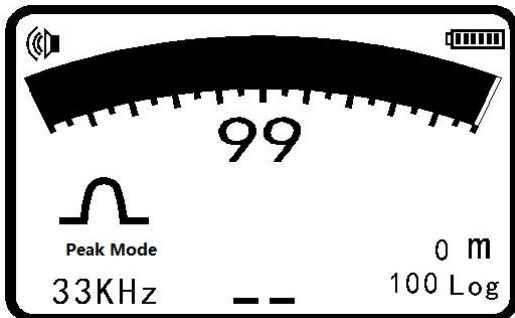



When there is an external A-frame, you can also select the external signal mode.



To increase, please press .

To decrease, please press .

In the adjustment, the number is shown in the middle of the display window.

Press  or  for 3 seconds to start the function automatically. The number turns into flashing cursor(as shown on the left), the instrument automatically adjusts the Signal strength to about 70% of full scale. The relative intensity of the signal is indicated by the

bar graph(8) above the display window and the number(9) below the graph.

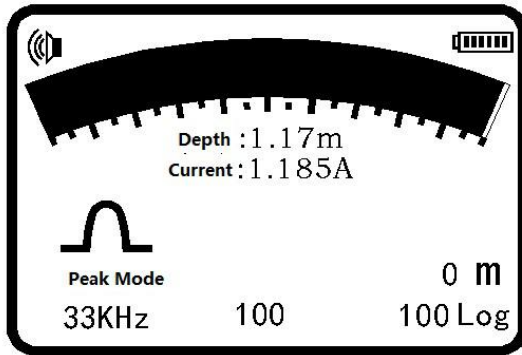

Depth/Current (5)



key is used to measure the depth of the buried pipeline, meanwhile it could measure the current value in the target line. In the current measurement process, regardless of the original use of which positioning mode, the system automatically switches to the peak mode.

The depth measurement unit can be selected by metric or imperial from the menu.

Metric Units: cm when the depth of the pipeline is less than 1 meter.

When the depth is more than 1 meter, the depth display unit is m.

Inch unit: feet.

Current unit: When the current is more than 1A, the display current unit is A, when the current is less than 1A, the display current unit is mA.

Note:

1, in order to measure the exact depth of the depth, the receiver must be maintained in the vertical position of the work.

2, in order to improve the accuracy of the depth of the measurement, it is not suggested to use the valley mode, the wide-peak mode is recommended for pipeline depth measurement.



Backlight (6)



Press the backlight key, the backlight of display will turn on and keep a preset time, and then press the backlight button, backlight is off.



The backlight time can be set via the backlight menu.

Data Storage:



Measured current and depth data storage method: After measuring the current value, the depth and current value are indicated in the middle of display. If you need to store data, press  button, the detection value is stored in the instrument's memory, and the lower right corner of the display indicates how much serial number (12) is stored. If

storage is not needed, press  button to restore the locating mode.

Browsing Data: After pressing  button and  button together for 3 seconds, it enters the interface including frequency, serial number, distance, depth and current, etc.

Press  and  button to visit the previous and next page. Press  again to exit. If no key is pressed for 20 seconds, it restores the locating mode.

Note: Only 1000 data of the same frequency can be saved. After switching to the different detection frequencies, if you need to store the data, you must delete the data of the original frequencies that have been stored before storing the new frequency data.

For example: the instrument has been stored 128Hz data group 100, now it is changed to the measurement frequency of 512Hz and needs to store 512Hz data to complete the measurement., Press  to store, Reminder: "128Hz has been stored 100 data, whether to delete", if you need to delete , press  for 5 seconds to delete to store 512HZ data.

1.2 Receiver Display



Battery Indicators (7)

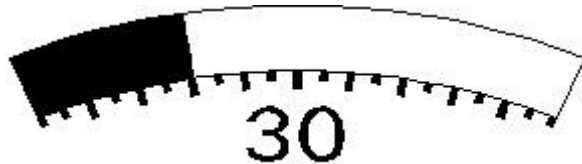

The upper right corner of the display has a battery symbol that indicates how much battery power is. When a flashing battery symbol is displayed indicating that the built-in battery of the instrument is not enough for work and needs to be recharged. Generally, the machine uses a high-performance lithium battery pack, fully recharged for the receiver to work more than 10 hours.

Receiver recharging: The charger's circular is connected to the receiver's charging jack, the other end is plugged into the 110V/220V power supply, charger indicator light is red during charging, and it will turn green after full charged.



Signal Strength (8、9)

The bar graph above the display window indicates the relative strength of the signal.

The number indicates the signal strength and it can be adjusted by pressing   . Display the lower side of the window with the number 0-100 to show the receiver's gain size. When the signal source is strong, it is necessary to decrease. When the signal source is weak, it needs to increase. When in the normal detection, it is necessary to adjust the signal strength to about 70% of the full scale.

Display (10)

Display a variety of measurement parameters and measurement results show.

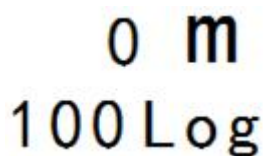

Point distance indication (11)

When the GPS is successfully connected and the satellite signal is received, the detection data saves the distance between the two measuring points and displays it in real time. If the GPS module is not configured and point distance will display 0m.

Data Storage Log (12)

Once the measured data is stored, the number will be automatically incremented by 1. 100 Log means that 100 groups of data has been saved and it could store 0-1000 data.

Speaker Indicator (13)



The loudspeaker indicator indicates the level of the speaker sound, the sound mode has high, medium, low and off. When the speaker sound is off, the speaker indicator is not displayed. The speaker volume is set in the menu settings.

Locating Mode (14)

Press  button to select modes (Valley mode, peak mode, broad peak mode and peak arrow mode) , and the mode is displayed.

Frequency Indicator (15)

Use the frequency key to select the desired detection frequency and the frequency will be displayed.

Increase/Decrease Indicator (16)

The number 0-100 in the lower side of the display shows the receiver's gain size. When the signal source is too strong, it is necessary to decrease. When the signal source is too weak, it needs to increase. During the detection, it is necessary to adjust the signal strength to about 70% of the full scale.

Left/Right Arrow Indicator

When using the valley mode or the peak arrow mode to detect the pipeline position, the left and right arrows could help to trace the pipeline position quickly. When the instrument deviates from the left side of the pipeline, the right arrow appears. When the instrument

deviates from the right side of the pipeline, the left arrow appears.

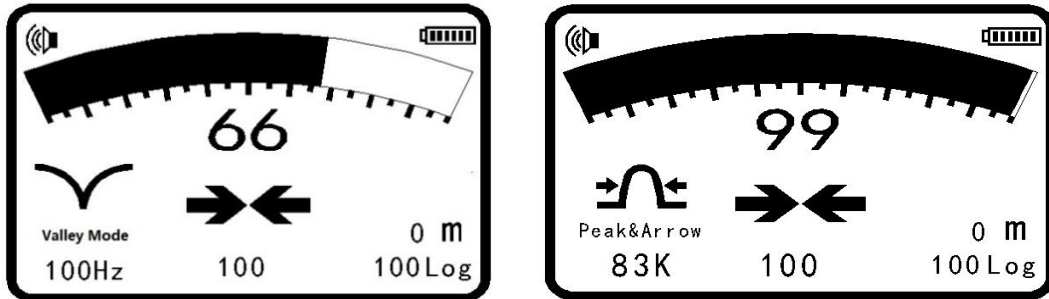

Coating Leaking Point Indicator

When testing damage points or cable failure points, the arrows will help to indicate the location of the position on coating (as shown below). When the forward arrow appears, the point of failure is in front of the A-frame. When the rear arrow appears, the point of failure is behind the A-frame.

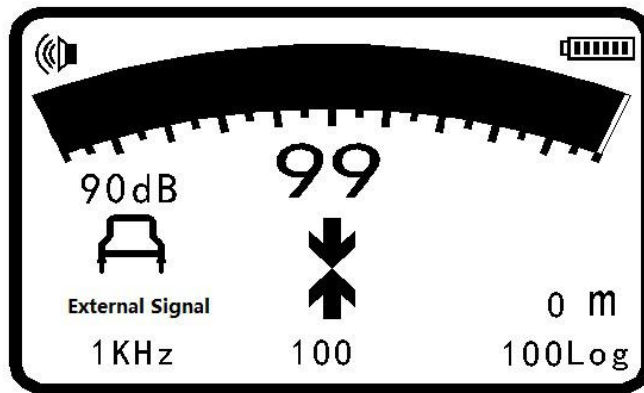





A frame access status

If A frame is connected, press  button to select the external signal mode. A frame is used to detect the damage point of the coating and shows the size of the damage point in dB.

Other Locating Method:

50Hz for power line signal detection, CPS signal (cathodic protection current signal), and radio signal detection.

1.3 Receiver Setting

Press  key for 3 seconds to enter the main menu. Press  or  to move the cursor. Press  to enter the submenu or change the setting. Press  to return the main menu.



Menu	1
Language	Chinese
Contrast control	Entry
British—Metric	meter
Speaker Volume	Low

English Menu 1



Menu	2
Backlight	15S
Automatic Shut	10min
Bluetooth Pairing	Entry
Search For Bluetooth	Using

English Menu 2

Language Setting: Move the cursor to Language and Press  to change the language between Chinese and English.

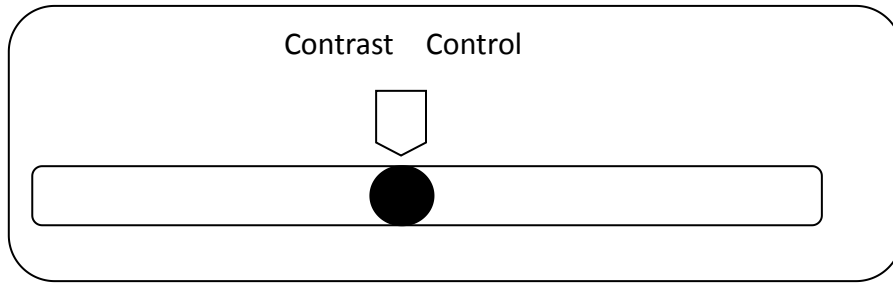

Contrast Control: Move   to Contrast Control and press  to adjust the contrast by pressing  or . Press  to return the main menu.





Measurement Unit Setting: Press   to move the cursor to British-Metric setting and press  to set Footage or Metric.

Menu		1
Language		Chinese
Contrast control		Entry
British—Metric		meter
Speaker Volume		Low

Menu		1
Language		Chinese
Contrast control		Entry
British—Metric		Feet
Speaker Volume		Low

Speaker Setting: Press   to move the cursor to Speaker volume setting. Press  to set the volume.

Menu	1
Language	Chinese
Contrast control	Entry
British—Metric	Feet
Speaker Volume	Low

Backlighting Setting: Press   to move the cursor to the backlight time setting.



Press  to set the time : 5S→15S→30S→1m→oftenlighting→Off→5S.

Menu	2
Backlight	15S
Automatic Shut	10min
Bluetooth Pairing	Entry
Search For Bluetooth	Using

Automatic Off Setting: Press   to move the cursor to automatic off setting.

Press  to set the time: 30 minutes→10 minutes→ 5 minutes→Never→30 minutes.





Menu	2
Backlight	15S
Automatic Shut	10min
Bluetooth Pairing	Entry
Search For Bluetooth	Using

Bluetooth: Press   to move the cursor to set the Bluetooth pairing. Press  to enter the Bluetooth pairing.

Menu	2
Backlight	15S
Automatic Shut	10min
Bluetooth Pairing	Entry
Search For Bluetooth	Using

Bluetooth Pairing

Searching.....

Bluetooth Pairing: Press   to move the cursor to "HOLUX_M-1200", Press  to confirm. Receiver is paired with GPS Bluetooth module and the icon in the display is lighted. The receiver can receive GPS data by the Bluetooth. Press  to return to the main menu.

Bluetooth Pairing



Nokia N70

TOK

HOLUX_M-1200

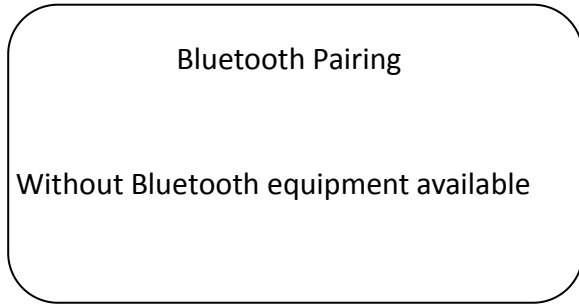
If there is no Bluetooth searched, it will display NO Bluetooth Equipment Available and press  to return to the main menu.



Bluetooth ON: Press   to move the cursor to Search for Bluetooth menu.

Press  to turn on/off the Bluetooth. (HZ-4000B is not equipped with GPS Bluetooth and the setting is forbidden.)

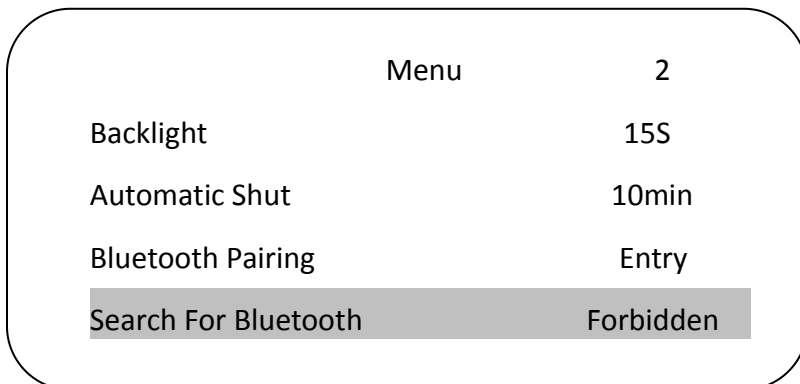
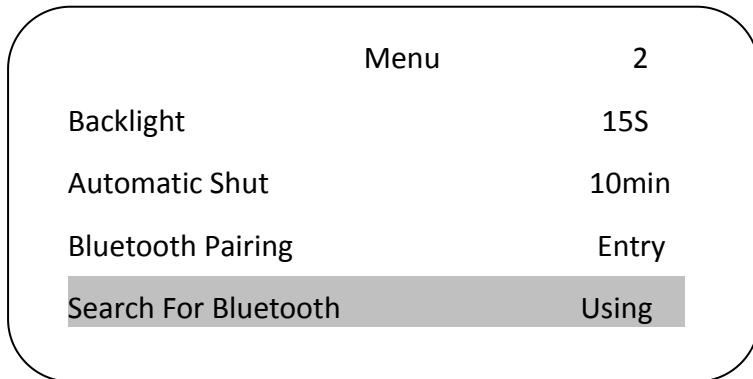

2.HZ-5000:Transmitter

The transmitter is adapted to apply a signal of the selected particular frequency to the target line, and the signal can be applied by the direct connection

method and the inductive method. Transmitter with power, measuring distance, automatic impedance matching, automatic measurement of pipeline grounding resistance and so on

Front Panel: 7 touch keys, 2 indicator lights and a LED display screen.

2.1 Keyboards:

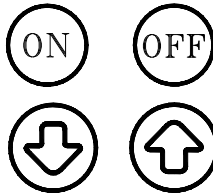

ON/OFF: To turn on/off the transmitter

Frequency: to adjust the transmitter power.

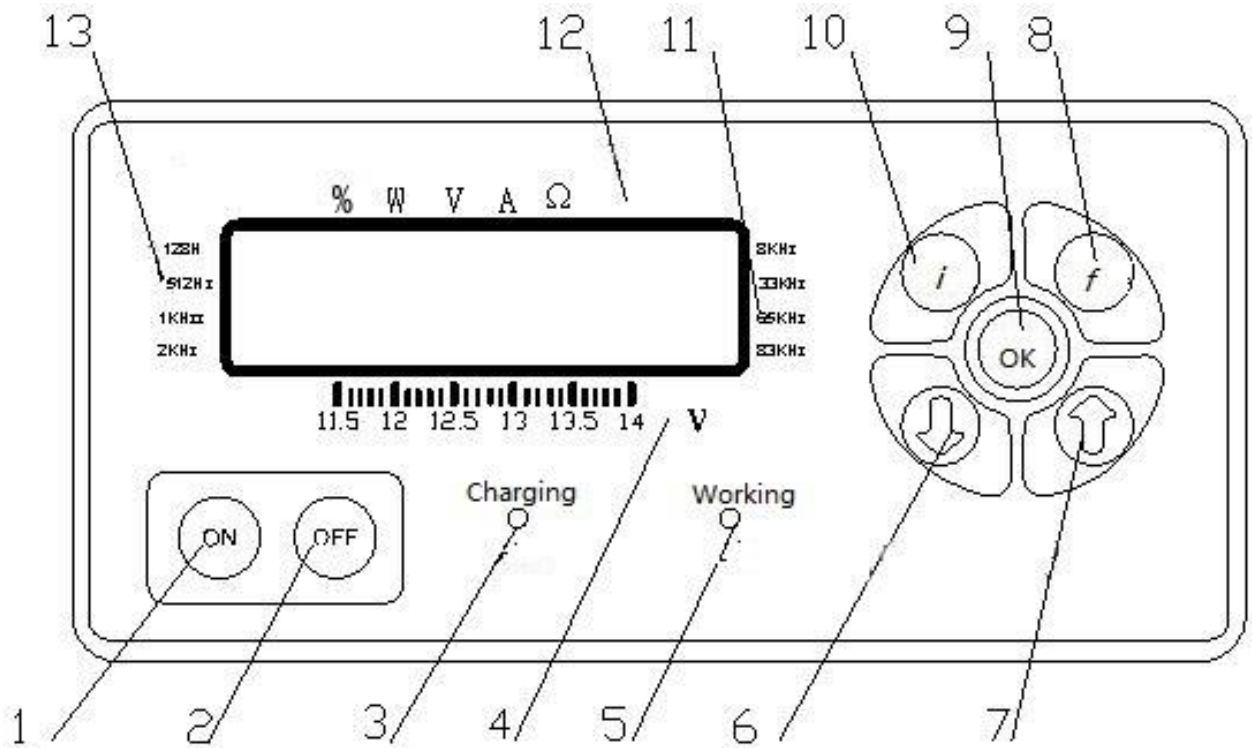

Front Panel

- 1&2.ON/OFF; 3.Charging Indicator; 4.Voltage Indicator; 5.Working Indicator;
- 6&7.Frequency Adjustment;
- 8. Frequency; 9. OK/Enter; 10. Measurement; 11.Working Frequency Indicator;
- 12.Transmitter Output Parameter; 13. Two frequencies of coating leak detector

Frequency (f): Select the frequency 128Hz, 512Hz, 1KHz, 2KHz, 8KHz, 33KHz, 65KHz,

83KHz.

Measurement (i): Press the measurement key to select the output parameters of the instrument:output power percentage, output power, output voltage, output current, output impedance.

Enter (OK): When you set the frequency to be applied, press the OK key again to change the transmitter output frequency immediately. If the key is not pressed after the frequency selection, wait for 5 seconds. The instrument automatically confirms the selected frequency.

Display

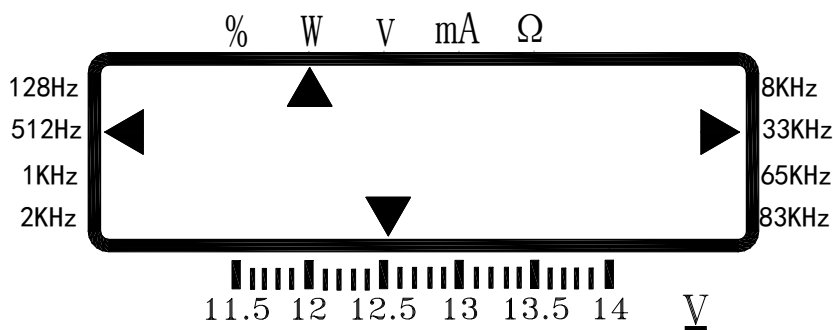

Working Frequency: When the frequency of the transmitter is selected, the corresponding triangular indicator light is on, and the available frequencies are 128Hz, 512Hz, 1KHz, 2KHz, 8KHz, 33KHz, 65KHz, 83KHz.

Voltage: The bottom line of the display shows the level of the supply voltage. When the triangular indicator corresponding to the supply voltage is on, it indicates the level of the power supply. When the supply voltage drops below 11.5 volts, the battery must be charged.

Output Parameter: The top line of the display shows the output parameters of the transmitter. The first indicator indicates the percentage of the output power in inductive mode. The second indicator indicates the output power. The third indicator indicates the output voltage. The fourth indicator indicates the output current, and the fourth indicator indicates the output impedance.

Display: The display has eight digits, the first four digits are used to display the measured value, that is, the transmitter output parameters (output power, output voltage, output current and output impedance), the seventh and eighth digits display the output level (from 0 to 10). When the output level is from 0 to 9, only the seventh digit shows the relevant value. When the output level is 10, the seventh digit shows 1 and the eighth digit shows 0.

2.2 Battery Recharging

When the transmitter battery voltage is too low, you need to charge it, you must turn off the instrument firstly (if the instrument is turned on, do not charge the battery because it can work), and then the power adapter is plugged into the instrument charging jack, insert the other end to 110V/220V power supply. When the charging is started, the charging indicator should be red. The charging light turns green after it is full charged.

IV. Specifications

1. Locator

Positioning accuracy: $\pm 5\%$ of depth

Depth measurement accuracy: $\pm 5\%$ of depth (no adjacent line interference)

Current measurement accuracy: $\pm 5\%$ of actual current

Depth measurement range: <6 m

Working mode: valley method, peak method, broad peak method and peak arrow method.

Operating frequency: radio, 50Hz, 100Hz, 128Hz, 512Hz, 1KHz, 2KHz, 8KHz, 33KHz, 65KHz, 83KHz (different operating frequencies according to different product models)

Working temperature: $-20\text{ }^{\circ}\text{C} \sim +50\text{ }^{\circ}\text{C}$

Battery: 7.4V lithium battery

Dimensions: 595mm \times 136mm \times 238mm

Weight: 1.6Kg (including battery pack)

2. Transmitter

Output power: 10W

Operating frequency: 128Hz, 512Hz, 1KHz, 2KHz, 8KHz, 33KHz, 65KHz, 83KHz

(different operating frequencies according to different product models)

Working modes: automatic conversion of three modes - direct connection, inductive connection and clamp connection

Battery: 14.8V built-in lithium battery pack

Working temperature: -20 °C ~ +50 °C

Dimensions: 348mm × 228mm × 84mm

Weight: 2.5Kg (including battery pack)

V. Parts and Accessories

No.	Item	Qty
1	locato	1
2	transmitter	1
3	Direct connection signal wire	1
4	Clamps	1
5	Output wires	2
6	Grounding rod	1
7	Chargers	2
8	Connecting magnet	1
9	Power line	1
10	A frame	1

VI. Check before use

Please check all the parts before using the locator and transmitter to ensure that the battery is sufficient and instruments are working well. In case there are any following conditions, please solve them before use.

1 .Locator check

1) Battery power check: press the power button to check the battery power. If the battery is fully charged, the battery symbol in the display will show all the five lines; when

the battery symbol has only one line, the battery symbol will flash indicating that the battery is low and it needs to be fully charged.



Full battery



Almost run out and please recharge

2) Operating frequency check: press the frequency key to select 50Hz and adjust the sensitivity. Point the locator to the fluorescent lamp 1 meter away and turn on the fluorescent lamp. A signal sound will be heard, and the monitor will display strong signal too.

3) Inductive method check: find a place without any interference and put the transmitter on the ground. Turn on the transmitter and select the output power percentage and frequency. Then point the receiver (about 5 meters away from the transmitter) to the transmitter and keep the same frequency as the transmitter. When the sensitivity is adjusted to be large enough, the receiver should have a signal response.

4) Clamp method: When the external clamp is inserted into the transmitter output interface, press the button ON, the transmitter will select the frequency as 33KHz automatically. Put the clamp on the target pipeline and adjust the transmitter power. Turn on the receiver and select the frequency as 33KHz. The receiver should have a signal response along the pipeline.

Note: For the Inductive method, you can only choose 65KHz and 83KHz frequency. Without the direct signal output or clamp inserted, the instrument will select the inductive mode automatically. In the inductive mode, only 65KHz and 83KHz are available; In the clamp method, you can only choose 33KHz. When the clamp accesses the transmitter, the instrument will select the frequency as 33KHz automatically.

When using the inductive method or clamp method, the instrument display shows the percentage of output power, and the triangle for percentage on the top line is lighted.

Three frequency output power corresponding percentage

Level	33KHz	83KHz	65KHz	Notes
0	0%	0%	0%	65KHz: 7 levels; 33KHz&83KHz: 9 levels
1	10%	10%	10%	
2	20%	20%	25%	
3	30%	30%	40%	
4	40%	40%	55%	
5	50%	50%	70%	
6	60%	60%	85%	
7	70%	70%	100%	
8	85%	85%	—	
9	100%	100%	—	

(1) Transmitter check:

To check the battery power: turn on the transmitter and observe the monitor battery power indicator light; if the battery voltage indicator is less than 11V, you need to fully charge the battery before use.

(2) Depth function check:

Select an area without any metal structure and other lines being detected, place an insulated cable or wire longer than 20 meters on the ground, connect it to the ground bar or directly to the ground. Connect the other end to the red wire (black wire to the ground) and insert the output cable into the transmitter's output jack. Turn on the transmitter, adjust the output signal, then put the receiver on the long wire with a known height to measure the depth. The receiver is placed vertically above the middle position of long wire, that is to say, 10 meters away from the transmitter. The depth is measured at different heights and the results are compared to the known heights to calibrate the depth.

(Note: if there is a metal object nearby, it will affect the accuracy).

VII. Ways of Pipe locating:

1. Applying signal

Underground pipeline detector field source has two kinds: passive and active source. The passive mode is used to search for an unknown power cable or an underground pipe to which a cathodic protection signal is applied and a metal line that is capable of sensing a radio frequency in a zone. The active mode of operation is used to track and locate the pipeline signals in the area.

1) Passive mode

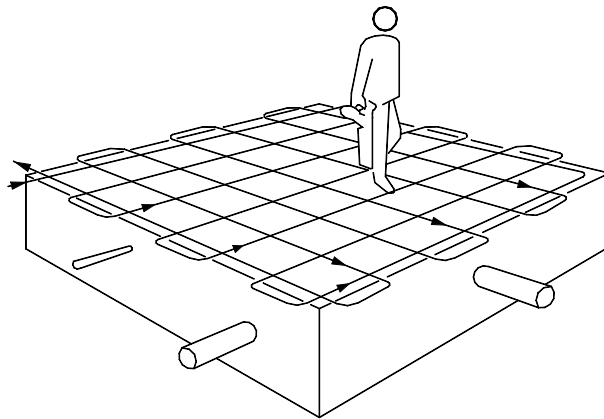

Passive mode: The transmitter is not needed for this mode. It can search for the power cable in an unknown area. Turn on the receiver, select the receiver operating frequency as 50Hz, adjust the gain to get a suitable reading and select the maximum or minimum method to grid search in a region back and forth search. Carry the receiver to walk steadily, so that the fuselage surface is aligned with the direction of movement and try to make it stay into the right angle instead of in the arc swing because it will produce some misleading signals. When the receiver responds with an abnormality, stop immediately and precisely position the pipeline and mark it. Traces and marks are also required for a pipeline that reaches out of the search area.

1.2 The passive cathodic protection current (CPS) signal method: It does not require a transmitter to operate. It can search for the underground metal pipe when applying the external current cathodic protection within an unknown area. Turn on the receiver, select the receiver operating frequency CPS and use the same method as 1.1.

1.3 Radio frequency detection mode: It is mainly used to detect the metal pipeline that is sensitive to the radio frequency.

2.Active mode

The active source operates by applying a signal of the specific frequency from the transmitter to the pipeline, and then positioning and tracking the pipeline with the receiver. Using the active mode can not only locate the pipeline accurately, track the pipeline and measure the depth, but also detect the coating damage points on the underground pipeline accurately and determine the size of the damage point of the coating.

Two methods: direct connection and inductive connection. Direct connection is the ideal way to track the pipeline while the inductive connection is the most convenient way to find the underground pipeline in the region.

(1) Direct Method

The transmitter is connected directly with the pipeline and produces the strongest signal in the pipeline. This method should be the priority in the probing pipeline. It is suitable for continuous tracking and positioning of various underground pipelines, positioning and depth measuring with high precision.

1)Connection

Turn off the transmitter and insert the connecting wire into the transmitter output jack. The red wire is connected to the target line (if it is a power cable, the power must be shut off). If it cannot be connected directly, connect the magnet to the pipe and then clamp the magnet, if necessary, clear the corrosive joints to ensure a good electrical connection. The other black wire is connected to the ground, which should be far away from the target line and at right angles to the possible direction of the target pipeline. Be careful not to route the ground wire across other underground pipelines to prevent signals from being affected on non-target pipelines. If there is no available grounding point, you can use the grounding rod into the ground; the black wire is connected to the grounding rod. If the ground connection is too dry, some water can be put here to improve the grounding effect. If possible, the grounding point should not be less than 5 meters from the transmitter.

2) Parameter Setting

Turn on the transmitter and the display shows the selected frequency, transmitter power and output parameters. According to the frequency required for measurement, select the option with the frequency key. Press the frequency key, the frequency triangle shape is lighted in the circle of 128Hz, 512Hz, 1KHz, 2KHz, 8KHz, 33KHz, 65KHz and 83KHz. Select the corresponding frequency of the lighted triangle. The display indicates the corresponding parameters (including output power, output voltage, output current and ground resistance) according to the triangle indicator, and the parameter display is selected with the measuring keys.

3)Grounding resistance check

The transmitter has a multi-meter function that automatically detects the ground resistance. Select the output parameters to the Ω level, the grounding resistance will be shown on the display. If the grounding resistance is too big, you must re-select the ground point or add water at the ground to reduce the grounding resistance. If the grounding resistance is too big, the power of the instrument cannot be increased.

Note: Be sure to connect the wires before the transmitter is switched on. If using direct connection method in underground detection, the cable power switch should be shut off first.

(2)Inductive connection Method

When the operator cannot directly apply the transmitter signal to the target pipeline, the inductive connection can be used. There is a transmitter coil in the transmitter. When the transmitter is turned on, the transmitter coil can directly sense the signal to the pipeline under the transmitter and the receiver can receive the electromagnetic field generated by the underground pipeline. The method is easy to use and there is no need to connect the target pipeline, but with the method, the receiver can also sense the signals from the adjacent non-target pipelines, and a portion of the energy is in loss of surrounding soil due to the signal attenuates.

The inductive connection cannot apply a signal to a pipe under a metal manhole or a

reinforced concrete pavement because the signal will be shielded by metal covers or steel bars. The inductive connection method cannot be used to apply signals to well-insulated pipelines unless both ends of the pipeline are connected to ground well.

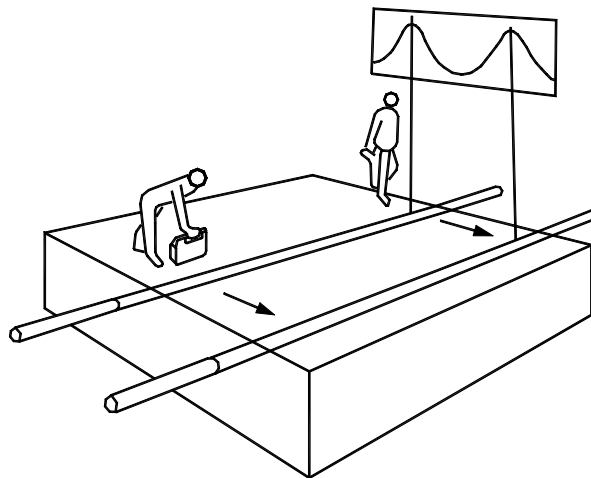

Illustration of inductive connection

1) Distance between Transmitter and Receiver

The transmitter will send signals to its upper space and the lower part of the pipeline at the same time, so the receiver will receive the signal from transmitter if it is close to the transmitter. In order to distinguish whether there is any effect on the receiver from the transmitter source, move the transmitter to one side by one or two meters, and if the anomaly detected from the receiver is also moving, it means that the distance between the receiver and the transmitter is too short and the received signal comes from the transmitter. Another method is to point the receiver directly to the transmitter, then if there is no change of the abnormal phenomenon or if the abnormality is increasing, then the receiver receives the signal from transmitter. If this happens, you should increase the distance between receiver and transmitter or reduce transmitter output power and reduce receiver sensitivity.

2) Placing the transmitter

Illustration of Placing Transmitter

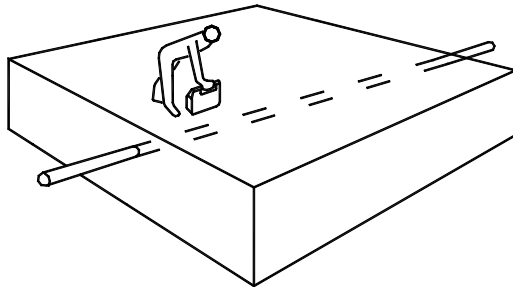

Illustration of Placing Transmitter

Place the transmitter on the "positive" side of the target line, and in the same pipeline direction to get better sensing signals.

Illustration of Placing Transmitter

1) Transmitter Frequency Selection

High-frequency signals are most susceptible to other pipelines. Please use high-frequency in the inductive connection. The high frequency signal will sense all the pipelines, so the inductive connection is the best way to find underground pipelines instead of tracking the pipeline. To track the pipeline it is ideal to use the direct connection.

General principles of frequency selection:

For high resistance pipelines (e.g. communication cables, pipes with coating and cast iron pipes), use the frequency of 83KHz. It must also be noted that the higher the frequency, the more easily it is sensible to other pipelines and the shorter transmitting distance;

For the general pipeline and cable detection, use 65KHz frequency which has longer transmitting distance and it is not easy to apply signals to other pipelines. It is suitable for long-distance pipeline tracking.

2) Transmitter power Selection

The transmitter power selection should be kept at the minimum level that meets the operational requirements, and increase the output power to the extent that a clear anomaly signal on the pipeline could be detected. If the output power is too high, it will apply the signals to nearby pipelines and this makes it more difficult to identify

the target pipeline and waste the battery power so the transmitter power selection should be appropriate.

(3) Clamp connection

The biggest difference between the clamp connection and the inductive connection is clamp connection uses an external clamp to apply the transmitter signal to the target line without the need for an inductive coil inside the transmitter. The method of clamp connection is basically same as the direct connection method.

1. Receiving and Locating

The Underground Pipeline Detector is used to position the target pipeline, measure the depth and the current in the target pipeline.

The position, direction, and depth of the target pipeline can be detected by the receiver when the signal of the transmitter is successfully applied to the target pipeline. Location and depth of the underground pipeline is the most important information and also the most important job.

1、 Location

When detecting the position of the target pipeline with the receiver, it is necessary to pay attention to the factors that may interfere with the positioning accuracy at any time, to prevent the transmitter signal from being overlapped with the adjacent pipeline, so that the detection result is deviated.

(1)Preparation

1) Check battery voltage: Turn on the receiver and check power. Fully recharge the receiver before use.

2)Frequency selection: Press Frequency key and set the required frequency. Set the same frequency with the transmitter if the active mode is being used.

3)Sensitivity setting: Adjust the up or down key to increase or decrease the receiver gain so that the bar reading is at 60-80% of the full scale.

4)Mode setting:

Press the mode key to select the appropriate operating mode as needed. The receiver provides peak mode, wide-peak mode, broad-arrow mode and valley mode.

(1) Peak(Maximum) Method

The peak method uses a single horizontal antenna (broad) or double horizontal antennas to receive the horizontal component of the target pipeline signal and the receiver gets the maximum response when the receiver is on the target pipeline. The single horizontal antenna wide-band mode is used to locate deeper pipelines with the highest signal sensitivity. When the receiver is directly above the detected pipeline, the signal strength is the largest, the response range

is wide but the positioning accuracy is lower than other methods. The double horizontal antennas peak mode has a steeper peak response than the single horizontal antenna wide-peak mode, the measurement position is relatively accurate but the signal strength is weaker. When the receiver is above the positioning pipeline, the signal strength reaches its peak.

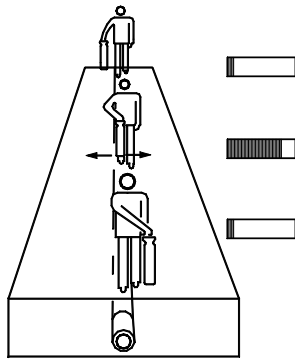

First of all, position the target pipeline. Generally, keep the receiver perpendicularly to ground with the receiver body pointing at the transmitter. If the signal is directly connected to the target pipeline, walk around the transmitter with the transmitter as the center and 5-10 meters Radius (if the inductive connection is selected, the radius need be greater than 20 meters), adjust the sensitivity so that the receiver maintains a certain static signal.

Move the receiver gently towards both sides in the presence of a peak response, find the exact location of the peak response and mark it, which is the location of the target pipeline.

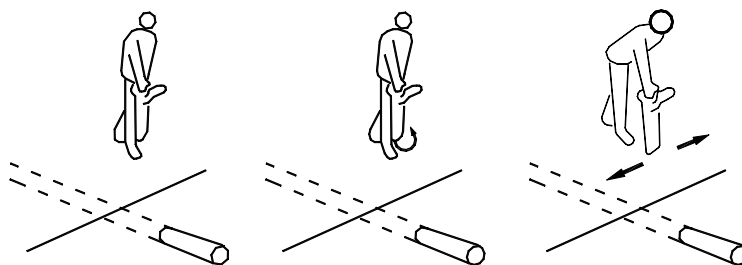

Illustration of Locating the Pipe with Peak Mode

Use the peak mode to locate the pipeline precisely: When the peak response point is found, stop and do not move the receiver, turn the receiver in the point, stop until the response reaches maximum, keep the receiver vertical, move the receiver above the pipeline, the point with maximum response is the location of the target pipeline.

On the target line, handhold the receiver and keep the receiver body perpendicular to

the pipeline and adjust the sensitivity so that the strength bar is between 60-80% of the entire range. Walk away from the transmitter, while moving the receiver to sides. When it shows that the middle is the peak with both sides diminishing, it means that the person who is locating is walking above the pipeline and he can make the long-distance tracking.

(3) Valley (Minimum) Mode

The valley (minimum) mode uses a vertical antenna to receive the vertical component of the target pipeline and the receiver receives a minimum response directly above the target pipeline. Valley (minimum) mode is intuitive, fast, but susceptible to interference and of poor accuracy. This method is mainly used to quickly track the pipeline and verify the accuracy of the response received from the peak method. The use of the valley (minimum) mode can speed up tracking the pipeline and you can hold the receiver at any angle because the zero value does not depend on the direction of the pipeline. When walking along the pipeline, the receiver can get the minimum value and the sound is the smallest above the pipeline. When the receiver is moved left and right, the reading of the strength bar will increase to a peak and the sound will increase too. Therefore, observe the zero value response and the peak response on both sides of the pipeline during the detection process.

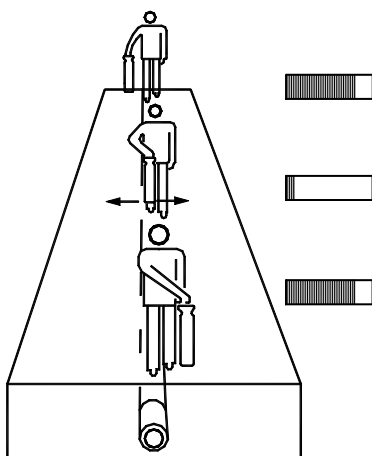
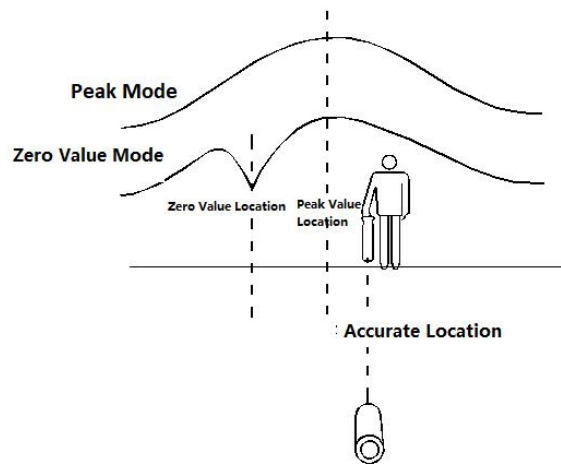

Illustration of Valley Mode

When using the valley (Minimum) mode to detect the target pipeline, it should periodically switch to the peak mode in order to verify the exact location of the target pipeline. Using the peak mode for fixed positioning and marking, and then switch to the valley (minimum) mode, mark the location of the pipeline valley (minimum) value. If the mark in peak mode and that in valley mode are same, then it can be considered that the positioning is accurate. If the two are not consistent, then the fixed-point positioning can be considered inaccurate. The actual location of the target pipeline should be close to the location of the peak mode.

(4) Peak arrow mode



Collation map between valley mode and peak mode

The peak arrow mode uses both a vertical antenna and two horizontal antennas to receive the vertical and horizontal components of the target line. The receiver gets the maximum value with a left and right arrow response when it is on the target line. If the maximum value is in the same direction with the arrow, you can think that the point of positioning is accurate. If the two are not consistent, then the fixed-point positioning can be considered inaccurate. The actual location of the target pipeline should be close to the location of the peak mode. With this method, there is no need to detect the peak and valley during the cycle of the switch. The operation is more simple and quick.

During the detection process, the strength bar will gradually decrease as the distance between the receiver and the transmitter increases, and it is necessary to hold the rising key to increase the sensitivity to compensate for the signal attenuation. If the receiver strength bar is suddenly reduced, stop immediately and re-detect the position of the pipeline at the point, increase the sensitivity and search the area round the radius of 2

m.

Possible reasons:

Pipeline is suddenly deepened. You can increase the sensitivity to continue the detecting.

There may be a "T" -shaped branch, and the pipeline may also change direction. Check whether more than one tube carries the signal in the circle. If the pipeline is more than one, measure the response of each pipeline from the distance away from the intersection of 4-5 meters. The strongest response comes from the main line and the weak one is from the "T" -shaped line. This is because the signal always selects long or large pipeline for the better earth circuit, which is very useful for detecting the main line and the branch line

The signal completely disappears probably because it has reached the end of the pipeline or the metal pipeline has been changed into a plastic pipeline or the pipeline is crossing a metal plate or cover. Please continue to detect.

When the signal is gradually reduced, and sometimes nothing can be detected by even improving the sensitivity. Then you can add the output power of the transmitter to the maximum, the pipeline can continue to be detected.

(1) If the signal becomes blurred and the signal distribution is very wide, pipes may be under the steel mesh net, which absorbs and sends out radiation signals. At this time raise the locator by 0.5m and minimize the sensitivity. You will be able to receive the signal and continue to detect without being affected by the concrete. In a variety of circumstances see Figures a to e as below.

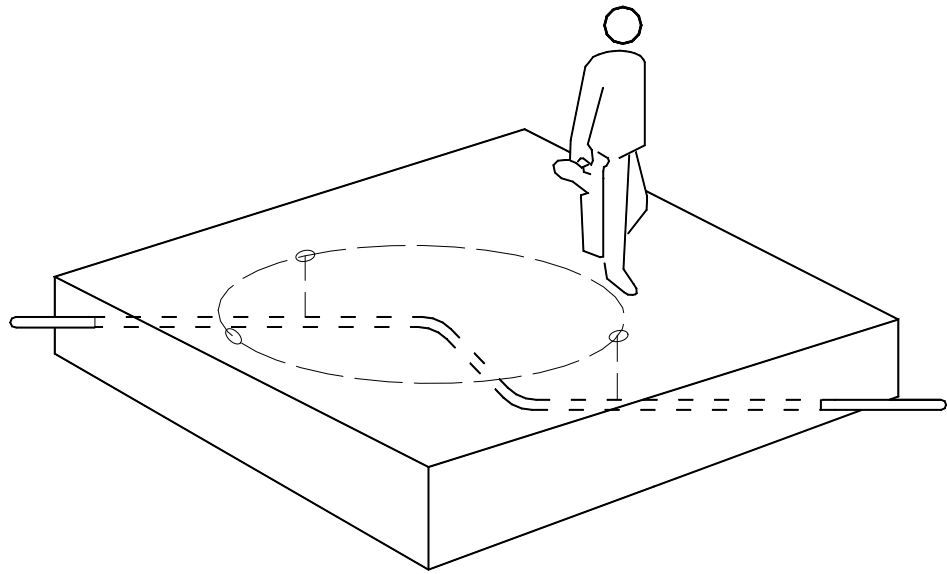

Figure a Illustration of Deeper Pipes

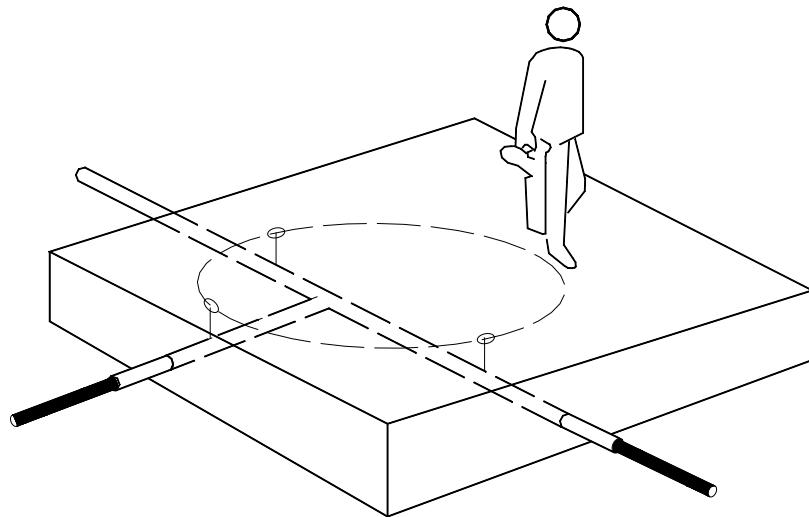

Figure b Illustration of T Branch Pipe

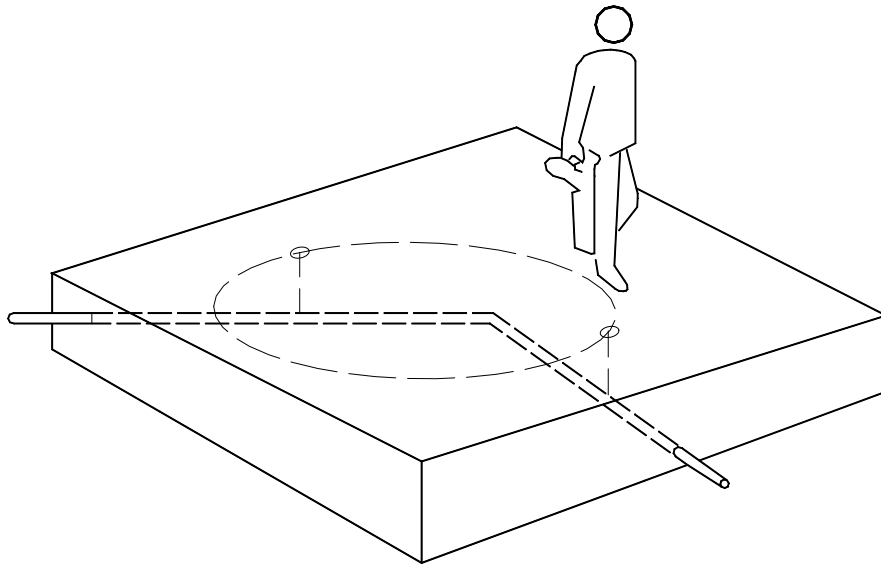

Figure c Illustration of the Pipe that Changes Directions

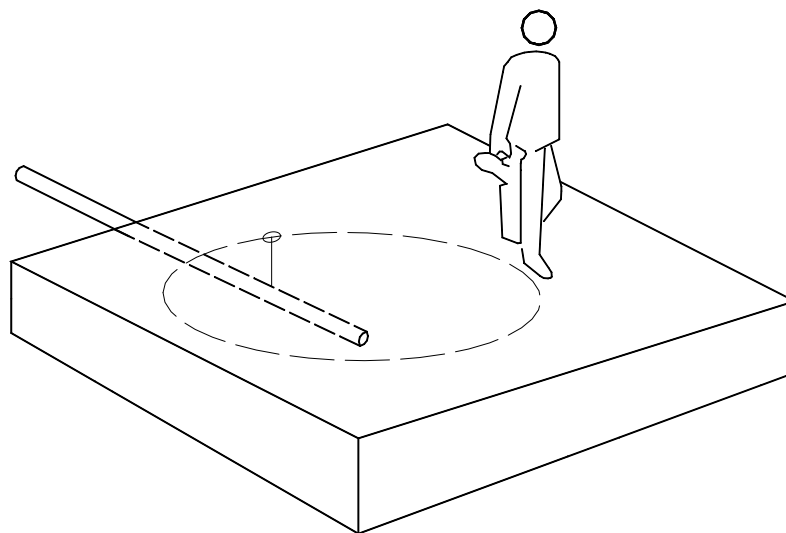

Figure D Illustration of Detection of Pipe Ends

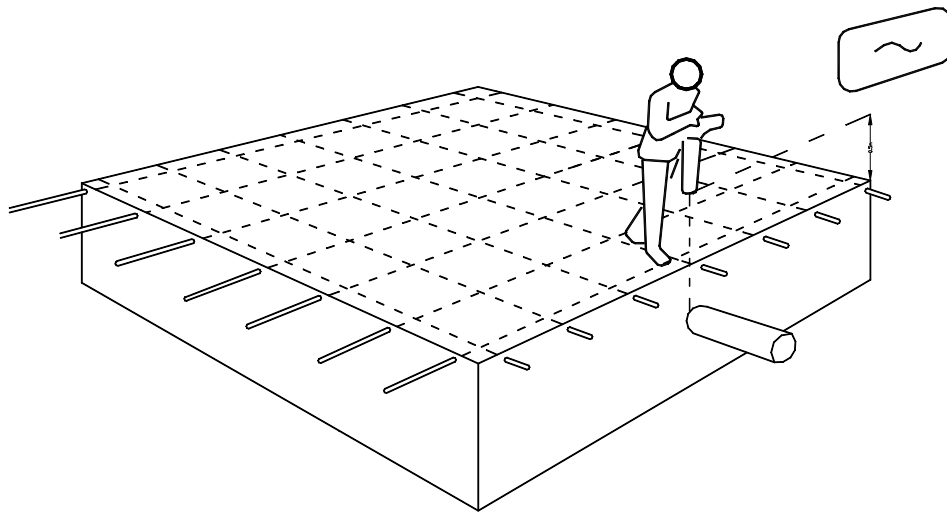

Figure e Illustration of Detection under Steel Mesh Net

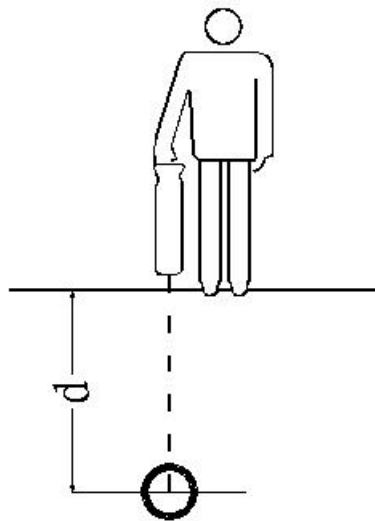



Illustration of Depth Measurement



2、Depth Measurement

This multi frequency locator can measure the depth of the target pipeline. Most commonly used methods are direct reading, 80% and 45 degrees methods.

(1) **Direct reading method:** to measure the depth of the range: 4.5cm-6m. When the range is exceeded or the signal is not normal, the receiver display shows an error message. Before depth detecting, the target pipeline should be accurately located by the receiver peak mode and the valley mode. If the two positions are inconsistent, there is interference exists. Depth should be measured when the peak mode and the valley mode are Consistent.

Place the receiver just above the pipeline and make the receiver body at the right angle with the pipeline and perpendicular to the ground. At this time it is better not to select the

vertical antenna mode. Press the  key and the receiver will automatically adjust the gain. After the gain adjustment is completed, the display shows: Testing. After 5 seconds, the depth of the target line and the current in the tube will be displayed and then press the  key to automatically restore the previous working status.

In depth measurement, a good quality signal is needed to be applied to the target line, when the key  is pressed, the receiver will automatically adjust the sensitivity to the best. If the receiver receives the too weak signals, the display shows the signal is too weak. Press the button  to restore the previous working status.

Although the method of direct reading is simple, it needs some conditions to read the correct results, otherwise the measurement is not so accurate and even the wrong result is obtained. One of the conditions for correct direct reading is that the positioning of the pipeline should be accurate, that is, the target pipeline position to be measured by the peak method and the valley method should be basically the same. Generally, it should be less than 20 cm, otherwise there is big deviation.

Depth measurement refers to the distance from the receiver bottom to the center of the target pipeline rather than the distance to the top of the pipeline, which cannot be ignored

when the target pipeline diameter is large.

If there is any doubt about the depth measurement, the result can be verified by putting the receiver 0.5 m above the ground and measuring again. If the measured value is increased by 0.5 m, the depth measurement is correct.

Depth measurement accuracy can reach up to 5% of pipeline depth if conditions permit, but operators do not know if bathymetric conditions are always appropriate. Please use the following technique to check for some readings:

Check whether the pipeline is straight. It should be straight at least within 5 meters on both sides of the measuring point.

Check if the signal within 10 meters is relatively stable. If it is stable, select several more points besides the original measuring point for depth measurement.

Checking if there are interference lines with coupled signals in the 3 to 4 meters range of the target line, which is the most common cause of error in depth measurements, and strong signals in adjacent lines may cause a depth measurement up to 50% deviation of the buried depth.

Depth measurements are taken at several points slightly off line. The most accurate depth reading is at the point where the depth is lowest and the position indicated that is the most accurate position.

(2)80%Depth Measurement

Place the receiver on the ground just above the target line and perpendicular to the ground. Select the single-peak antenna peak mode, adjust the sensitivity to a suitable value, and then move the receiver left and right in the vertical direction of the pipe until the strength bar drops to 80% of the value when it is just above the line. Mark these two points and measure the distance between them, which is equal to the buried depth of the target pipeline.

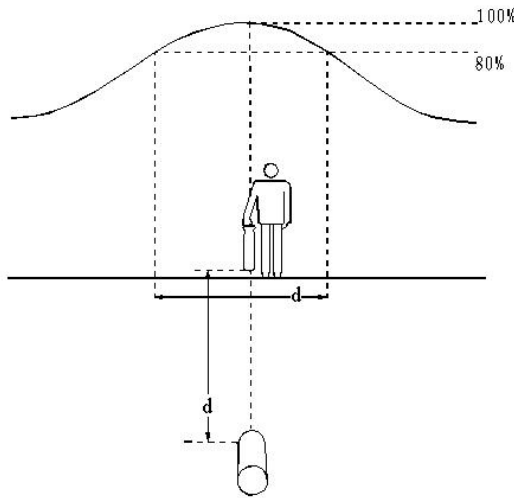

Illustration of 80% Depth Measurement

(1) 45 Degree Depth Measurement

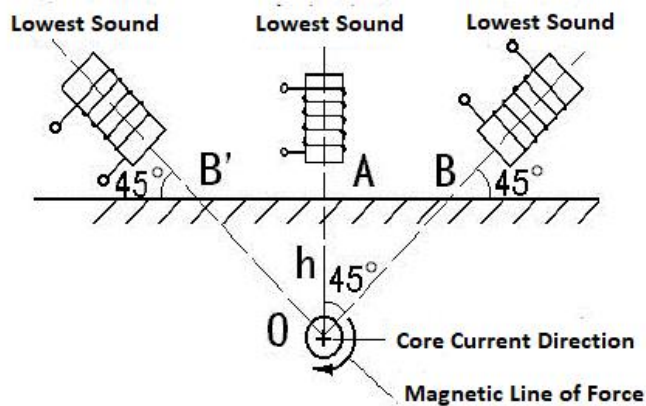

Illustration of 45 Degree Depth Measurement

First of all, measure the accurate location and direction of the target pipeline and switch the receiver mode of operation to valley mode, put the bottom of the receiver on the ground above the pipeline, adjust the receiver body to the ground at a 45-degree angle and move the receiver along the direction perpendicular to the pipeline. When the received signal is the minimum value, mark the point on the ground. The distance between the marked point and the measuring point is same as the buried depth of the pipeline.

The above several depth measurement methods are often used to verify the accuracy of depth measurement during the detection process, of which 80% is the most

commonly used and it is relatively accurate especially in complicated pipe network. The 45 degree measurement needs to master the receiver body Angle with the ground. Direct reading depth method used in complex environments often comes with big deviation. It is more suitable for long-distance single buried pipeline depth measurement.

(1) Current Measurement

Compared with the traditional pipeline, this underground pipeline detector can also measure the current on the target pipeline, which can help operators better identify the target pipeline. In pipeline intensive areas, the receiver may detect a stronger signal on the interfering pipeline than on the target pipeline because it is shallower than the target pipeline. In this case, it is difficult to accurately distinguish the target pipeline from the interference pipeline if only the signal strength is measured. The current measurement function can effectively distinguish between the target pipeline and the non-target pipeline. The pipeline with the largest current measurement data (rather than the strongest signal) is the one to which the transmitter signal is applied (see Figure f). Measuring current can also provide useful information about tees and elbows. Current measurement of the main line behind the tee can help determine the main and branch lines (see Figure g) because the main line draws more current due to the length (see Figure g).

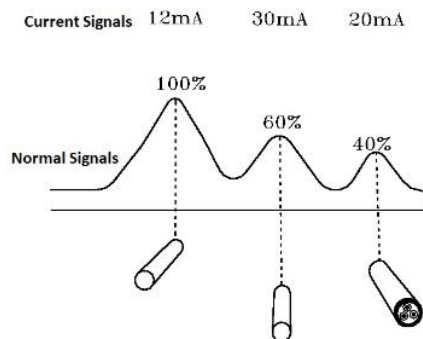

Figure f: Illustration of Current Measurement

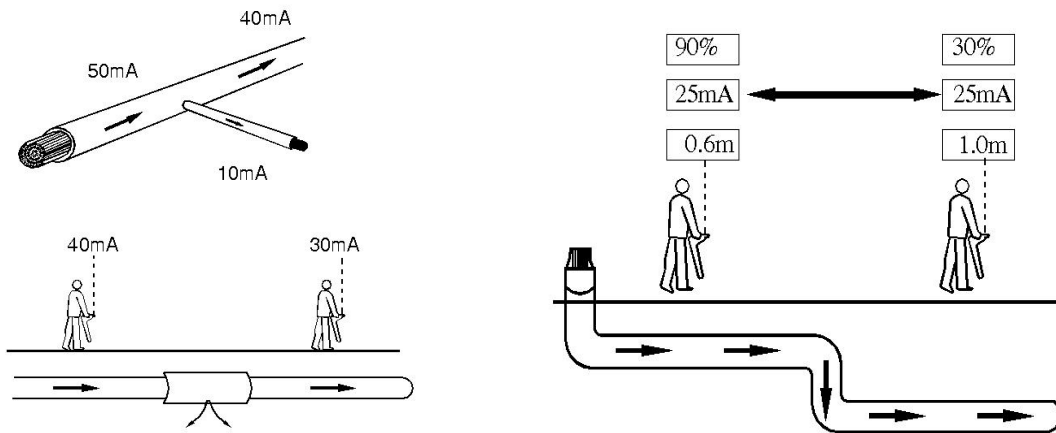

Figure g: Tee and elbow at the current measurement diagram

Principle of Current measurement: the transmitter applies a current signal to the target pipeline. As the distance from the transmitter increases, the current intensity will gradually reduce and the degree of attenuation depends on the pipeline type and soil. However, for one type of the pipeline, the current attenuation will be steady without a sudden drop or change. Sudden changes in current indicate that the pipeline or its condition has changed. (See figure h)

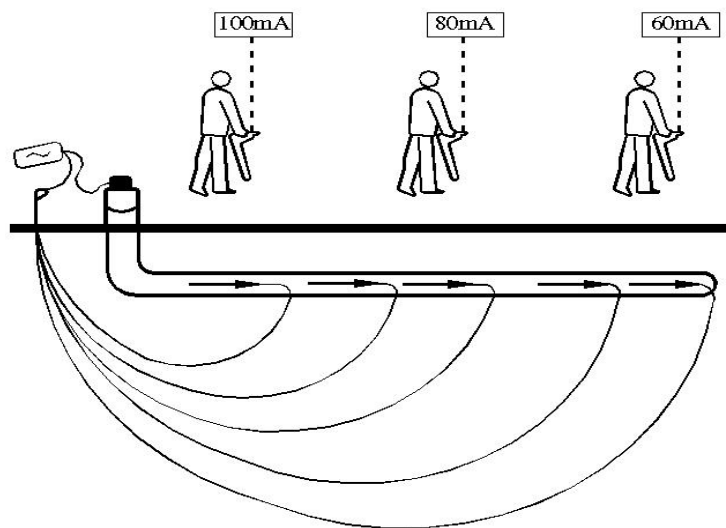

Figure h: Illustration of Principle of Current Measurement

Current measurement method: current measurement method is exactly same as the depth measurement and the current value will be displayed together with the depth measurement.

If the signal of the adjacent pipeline is received, this will reduce the measurement

accuracy. If the measured value is suspicious, search the nearby areas and check the nearby lines for other radiated signals. Depth / current measurements should be taken to other points of the pipeline if other signals cause interference.

VIII. Procedures of Detection

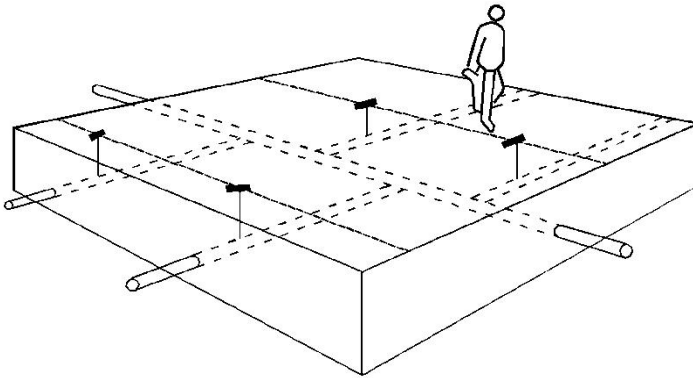

1. Material Preparation and On the Spot Research

This underground pipeline detector can locate all buried metal pipes and cables in one area. Therefore, the information on the buried depth and location of the pipelines detected by the underground pipeline detector helps to predict the distribution of underground pipe network before the construction of the new project. Before using the pipeline instrument, the information about detection area should be collected first. Although sometimes these data are not very reliable or accurate, but they can also provide some information about the pipelines in the area to be explored, and the sites: manhole covers, street lights, and signs indicating that there are buried pipes and cables need to be considered.

2. Power Frequency Grid Scanning

The receiver is able to test the frequency of the power cable at 50Hz. This method can quickly detect the position and orientation of underground power cables in the detected area and does not require a transmitter.

Press the receiver frequency key and select 50Hz frequency and a working mode. Take the peak mode as an example to illustrate the detection method: adjust the sensitivity so that the signal strength is 60-80% of the full scale. Scan the area in the grid-like route. Make sure the direction of the receiver is consistent with the direction of the pipeline and

is at right angles to the measured pipeline. When the receiver response increases, it means that there is a pipeline. Stop and position the pipeline accurately. Mark the location of the pipeline and trace the pipeline until it leaves the detected area. Then return to the area and continue network scanning.

Mark each pipeline location that has a signal response, then trace the portion of the pipeline outside the area and mark it.

3. Inductive Search

Inductive search is the most reliable technique for detecting unknown pipelines. This method requires a transmitter, a receiver, and two inspectors. This search method is called "two-person search method." Before starting, determine the areas to search for and the possible directions through which the pipeline passes. Turn on the transmitter, select the working mode as inductive connection and the same frequency. One inspector operates the transmitter and the other operates the receiver. Apply the signal to the pipeline when the transmitter passes through the pipeline and the receiver can detect the signal 20 meters upstream or downstream of the transmitter. The direction of the transmitter is consistent with the estimated direction of the pipeline. One person holds the receiver at the beginning of the area to be searched and the direction of the antenna of the receiver is kept perpendicular to the direction of the possible underground pipeline. The receiver is adjusted to the highest sensitivity that will not receive the transmitter signal directly from the air. When the direction of the transmitter and receiver is correct, the two operators move forward in parallel. The operator carrying the receiver moves the receiver back and forth while moving forward. The transmitter applies the signal to the pipeline directly below and the receiver detects the signal. Mark the ground at the receiver's detected peak position. Repeat the search in other directions where there may be a pipeline crossing.

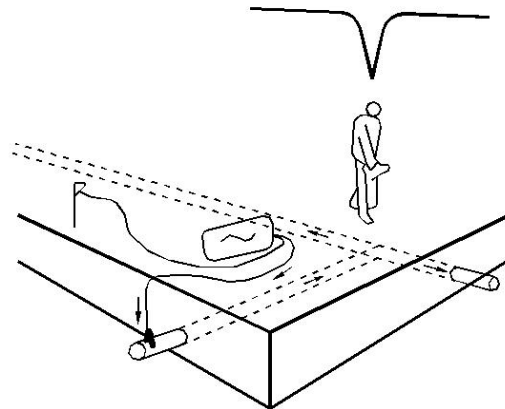

Illustration of Induction Search

By means of induction search, you can detect the missed pipeline of the passive search and other pipelines that do not sense the 50Hz signal.

Technique:

Keep the distance between the receiver and the transmitter. In the inductive connection mode, the transmitter emits signals to the target pipeline and also sends signals into the air, which may cause interference in the detection work near the transmitter. The inspector needs to check that the receiver is detecting the signal in the pipeline instead of the signal directly from the transmitter. Move the transmitter a meter or two. If the signal from the pipeline also moves along with it, this indicates that the receiver is too close to the transmitter. Another way to check whether a receiver receives a transmitter signal is to point the receiver to the transmitter. If the signal strength does not change or increase, it means that the receiver received the signal directly from the transmitter. In this case, reduce the transmitter output power and the receiver sensitivity. The receiver may also have to leave the transmitter 25 to 30 meters away. Do not place the transmitter on the manhole cover as this will prevent the signal from being applied to the target pipeline.

2. Pipeline Tracking, Positioning and Depth Measurement

Apply the transmitter signal to an accessible location on a buried pipe or cable such as containers, valves, street lamps, etc., track the area outside of the pipeline and make a mark.

For those Pipelines that need to be detected, they can be traced till they reach covers,

street lights and fire hydrants, etc. on the ground. Then apply the transmitter signals on them and trace it from this position back.

Position and Measure the depth of key points and feature points of various pipelines in the area, mark at each detection point, record relevant pipeline data and detection results, and then sort the data recorded and draw the pipeline map.

IX.Common Pipe Detection Techniques

1.T- Shape Detection

Once the tracking of the pipeline has been completed and markings have been made, the receiver can be used to track the pipeline once more. However this time it is traced about one meter away from one side of the pipeline that has been detected and parallel the receiver with the line. At this time no signal from the main line (or signal is small) can be detected, but the response to the branch can be significant.

The most reliable way to locate the branch pipe is to apply the transmitter signal to the end of the branch pipe. This signal will flow from the branch to the main line and then to both sides of the main line. The receiver surface is at right angles to the main line and the signal is tracked along the main line. The receiver will have a zero response above the T-branch joint. The zero position is the exact location of the T-branch joint.

2.Parallel Pipeline Detection

Parallel pipelines are a common phenomenon in pipeline detection. In pipelines intensive areas, receivers often receive interference signals from nearby pipelines. This will give us difficulties in the identification and tracking of target pipelines, positioning and the depth accuracy. Therefore, we must adopt some methods in our work to minimize the influence of the coupling signals of adjacent parallel pipelines.

First, do not use inductive connection in pipelines intensive areas. Instead, use the direct connection method to apply a transmitter signal to the target pipeline. In addition, lower transmitter frequencies can be selected to reduce signal coupling. In this case, peak mode positioning should be used and 80% method for depth measurement can reduce

the deviation.

In general, the response of the receiver to the target pipeline should be greater than to the nearby pipeline. The target pipeline can be identified and tracked by the receiver's response. However, if the adjacent pipeline is closer to the surface, the receiver's response to the nearby pipeline may exceed the target pipeline. The target pipeline cannot be identified and tracked only from the response of the receiver. At this time, we need to measure and compare the current of the signal on the target pipeline and the adjacent pipeline. The pipeline with the highest current value is the target pipeline to which the transmitter signal is applied.

If there are several parallel lines and the transmitter cannot be connected directly, each line can be probed by applying the line signal. Firstly, the whole area is searched by inductive connection method to find out the number, general position and direction of pipelines in the area, and marks are made on the ground. Then place the transmitter flat on the ground and as far as possible in line with the underground pipeline and ensure that the pipeline is directly below the transmitter so that the signal directly below the transmitter is zero, but other pipelines can detect it and move along the pipeline. Keep on moving the transmitter and marking the pipeline position. Finally, the first pipeline is traced outside the search area until the target pipeline can be accurately positioned.

3.Deepen Pipeline Detection

If the signal detected by the receiver suddenly becomes small during the detection process, the target pipeline may be branched or the pipeline may become deeper. First, find out according to the detection method of the T-line whether there is a branch line. If there is no branch line, the line may suddenly become deeper. Then, stop immediately and track the position of the pipeline where the signal strength drops rapidly. Adjust to high sensitivity, center on the signal response falling point and in the radius of 2 meters operate arc detection.

4.Dealing with Interference Signals.

Signals sensed from the adjacent pipelines are the most common problems

in pipeline detection, which may result in inaccurate position or depth measurement of the target pipeline or detection of an incorrect pipeline. In many cases, a certain degree of induction is unavoidable, but by using on-site inspection experience, some methods can be used to reduce the degree of induction, thus improving the reliability of detection.

Try to avoid using the inductive connection method to apply the signal, because the inductive signals may be applied to multiple underground pipelines.

Determine the locations where underground pipelines are complex and relatively close to each other. Detect from the simple point of the pipeline to the complex underground pipeline area, instead of starting from the complex underground pipelines. For example, if there are water pipes, gas pipes, power cables, etc. in a building, the signals should be applied from valves or other access points outside the building instead of signals from the building.

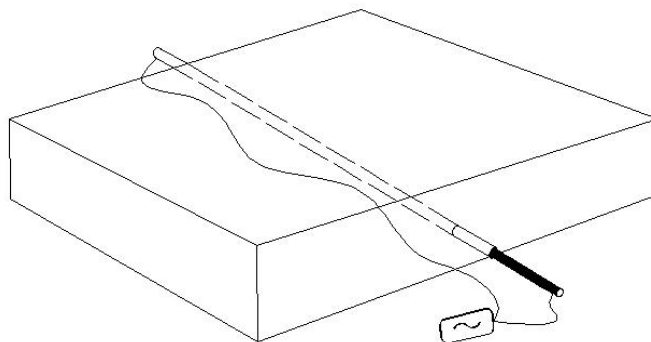

Illustration of double-ended connection

Use lower frequency signals if possible to reduce the response to the adjacent pipeline.

If the signal returns to the transmitter through another pipe, double-ended connection can be used to bypass the ground loop. Because when using the single-ended connection method, the ground loop signal goes back to the transmitter through other pipelines. Sometimes the loop signal may be stronger than the target pipeline signal because the target pipeline is deeper than the signal-carrying pipeline or the loop pipeline is more conductive than the target pipeline. There will be problems with the detection of the target pipeline. If there are access points at both ends of the pipeline, using the double-ended connection method to connect the transmitter is the most effective way to identify the target pipeline under intensive pipeline conditions. The specific operation is as follows:

The transmitter is connected to an access point in the target pipeline, and the

transmitter's ground is connected to another access point in the target pipeline through a long wire. This eliminates the need for grounding to form a complete circuit. The long pipeline should be far from the possible direction of the target pipeline.

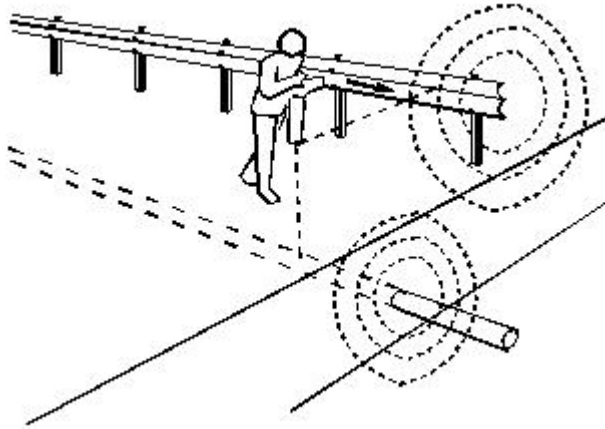

Illustration of Cable Detection of the Fence

5. Some Problems in Power Cable Detection

Before applying the transmitter signal, it is necessary to disassemble the common connector on the cable so that the target cable can be traced. If you want to track all the cables starting from the transfer box, you can make the transmitter work in inductive connection mode, place it on one side of the transfer box and align it with the cable to be tracked.

In order for the transmitter signal to travel a sufficient distance, it is necessary to remove the ground connection of the cable.

Power cables that have a ring in the ground will weaken the response on the cable path. At this point, the search range should be increased and return to the point before the response change. The receiver will be able to determine all the wire loops except the minimum in the cable.

Most cable connectors will show a peak pulse signal at the receiver. The experience of on-site detection and understanding of the actual situation can determine whether the peak pulse signal indicates a junction box.

The cable is usually buried directly under the road outside the metal fence on the road, and the signal will be coupled to the metal fence. Because the metal fence is close to the antenna at the bottom of the receiver, tracking becomes difficult. Lift the receiver so that the antenna in the lower middle of the body is in the same level with the metal fence. This problem can be solved.

The fact that the transmitter signal is connected to the metal pillar of the street light is almost as effective as the metal shield of the lighting cable itself, because the metal shield of the lighting cable can generally be connected to the metal pillar.

For cables coming from wooden poles, concrete poles or lighting columns, the transmitter can be placed in an inductive mode and the signal is applied by lining the pole at right angles to the ground.

6. Some Problems in the Detection of Cast Iron Pipes

This underground pipeline detector can be used to search for steel pipes and cast iron pipes with isolated interfaces.

Some cast iron gas pipelines and tap water pipelines have insulated joints. Transmitter signals can be applied to the gas meter or water meter. By using jumpers, the insulating gaskets are bypassed (a connecting magnet can be used on both sides of the insulating gasket to ensure the connection of magnets. Make sure the pipes are well connected and the two connecting magnets are connected by wires) so as to guarantee a reliable circuit for the cast iron pipes entering the house.

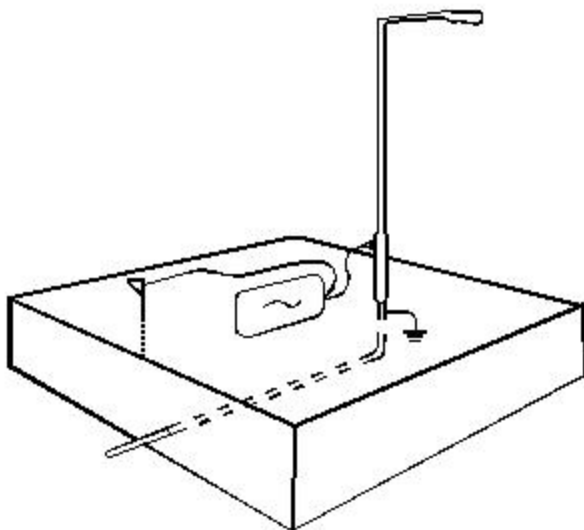

Illustration of Power Cable of Street Lights Detection

If you want to locate the pipeline on or near the road, you can use a single-ended connection method to connect the transmitter to the valve, and connect the ground cable to the metal frame of the valve box. Make sure the connecting magnets are in good contact with the pipes. If necessary, remove paint and rust before connecting.

Sometimes there may be some insulated joints in the pipeline. The transmitter with higher signal frequency should be applied to the pipeline behind each joint. This will be tested segment by segment until the entire pipeline is detected.

Combining the above methods can generally successfully track cast iron pipes.

X.Anti Corrosion Coating Inspection

The fault location is to detect the coating damage of the underground pipeline (pipeline fault refers to the damage of the outer anti-corrosion layer and the cable fault refers to the damage of the outer sheath). When there is a fault point, a part of the signal will return through the fault point through the grounding rod.HZ-5000 model can locate the fault in the underground pipeline using the A-frame. Specific steps are as follows:

- (1) Frequency selection: When using the A-frame to find the damage point of the underground pipeline anti-corrosion layer, it is recommended to use two frequencies of 128Hz or 512Hz.
- (2) Target pipeline positioning: Position the target pipeline with the receiver to determine the general area of the fault. If there is an abnormal signal loss during the pipeline tracking, it may be that part of the signal leaks from the insulation breakage into the ground.
- (3) Connection of the fault detection line: Insert the fault detection line or A-frame cable into the receiver input jack.
- (4) Receiver mode settings: Adjust the receiver mode key and select the external signal mode.
- (5) Use the A-frame to position fault points

The electric potential flowing through the A-frame can be detected by HZ-5000 Receiver, and the leaking insulation of the buried pipeline to the ground can be found through the change of the potential reading (outer sheath of the steel pipe and the outer sheath of the

cable).

When using the A-frame to detect along the pipeline, insert the A-frame every three or four steps. As you gradually approach the point of failure, the receiver signal will increase and the gain will need to be adjusted to reduce the sensitivity of the receiver. If the signal starts to increase, the detection speed should be slowed down, and each small segment of the ground should be carefully checked to prevent ignoring the point of failure. The receiver's strength value will continue to increase until there is a probe across this point of failure. When the fault point is between the two pins, the current will decrease and the reading value will approach zero. Adjust the gain and keep the readings at a higher value while moving the A-frame. Moving about 30 centimeters each time until a minimum reading is produced. At this point, the point of failure is between the two probes on the A-frame

Illustration of Positioning Fault Point using A Frame

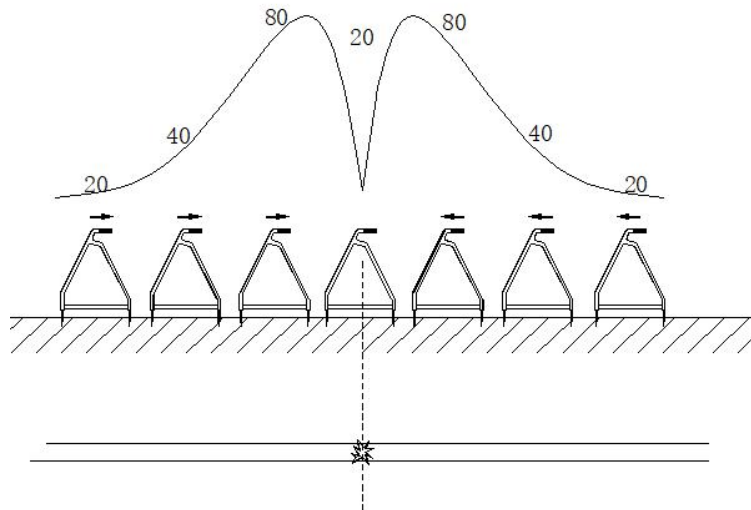

Illustration of A Frame reading

If the position of the pipeline cannot be determined during the fault point search, the mode key needs to be pressed at this time and the working mode need to be switched to the single horizontal coil, double horizontal coil or vertical coil to accurately position the target pipeline. After the positioning is completed, press the mode button again to select the external signal working mode and continue the fault point search.

It can be seen from the above figure that when the A-frame approaches the fault point, the receiver's horizontal signal will gradually increase (the readings in the figure are only diagrams, indicating that the signal size changes with the detection position).

When it is necessary to accurately locate the fault point, the accurate position of the fault point can be found when the A-frame is turned to be perpendicular to the cable. At this time, the location of the A-frame is directly above the point of failure.

If the cable is under the cement and asphalt pavement, special signal pick-up probes can be used, which can effectively solve the problem that other instruments cannot be tested on cement and asphalt pavement. If necessary, you can use water to wet the road. This will be better.

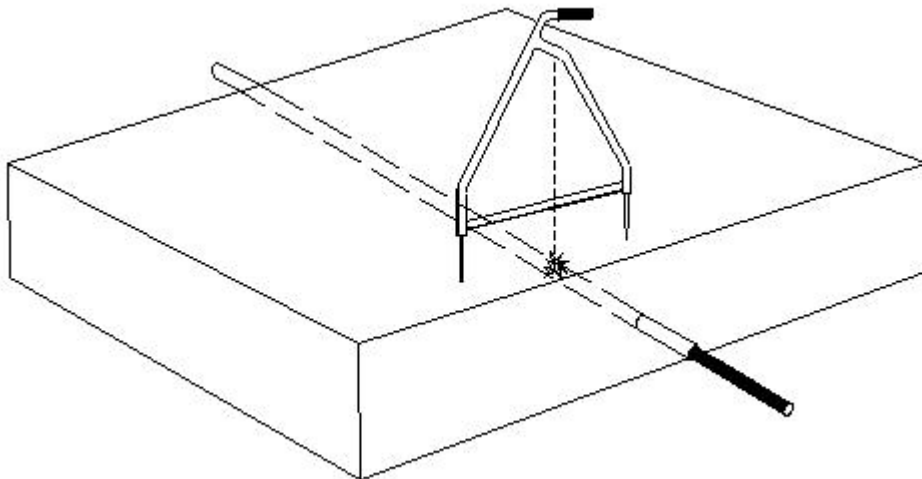
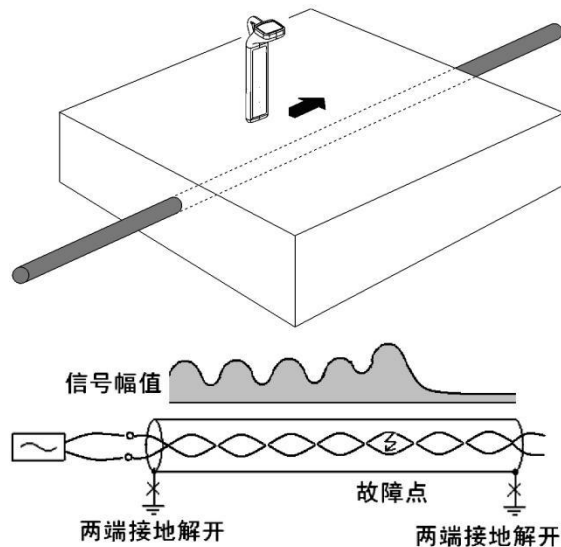

Illustration of Using A-Frame to Accurately Locate Fault Points

XI.Cable low resistance and broken line fault points



This chapter is an auxiliary chapter, please choose to read as necessary.

When the cable fault resistance is low, if the legal point of high-voltage impact discharge is adopted, the discharge sound at the fault point is weak, especially if there is no discharge sound in the fault of gold property dead earth, and the accurate fixed point of acoustic measurement method fails, audio induction method should be changed. The audio frequency method is generally only applicable to low resistance fault with resistance less than 10 ohms. A satisfactory result can be obtained by using the audio induction method to the two-phase or three-phase short-circuit (or combined ground) fault point, and the error of the general point is 1-2 meters.

Audio legal points can also be used for broken wires.

1. Phase-to-phase short circuit fault point

1) Signal transmission method

As shown in the figure, the two ends of the metal sheath of the cable should be earthed first, and the zero line and ground line grounding of the low-voltage cable should also be earthed. The transmitter should be directly connected with the output to connect two fault core wires. The receiver must be moved parallel to the cable and detected using the peak method.

2) Fixed-point method

Due to the cable core along the cable twisting path forward, therefore, when on the point of failure front the cable path forward, signal amplitude has the rule changes, according to cable torque, when located above the failure point, generally will be the strongest signal amplitude, and continue to move forward from the point of failure, the signal is reduced to a stable and very small amplitude. The receiver works best in historical curve mode, and its display will be similar to the signal amplitude curve shown above.

- 3) Matters needing attention:
- Applicable fault resistance: Measurements with a multimeter should be close to 0, up to 10 ohms. If it is higher than euro 10, try to burn it to low resistance first. Measuring pointer to zero with megometer (swing meter) cannot indicate low resistance fault, it must be measured with multimeter.
- The grounding of the metal sheath of the cable must be completely unwound, and the grounding of the zero and ground wires of the low-voltage cable should also be unwound to avoid interference from other signals.
- Before the fixed point, the path should be searched in advance and marked, otherwise it is easy to disturb the rhythm of the rise and fall of the signal.
- Note that the receiver direction should be parallel to the cable path and use the peak detection method.
- Due to the use of interphase wiring, the effective signal is very small, using high frequency signals will be easier to detect than low frequency signals. But the residual of high frequency signal after the fault point is also large. The frequency can be selected according to the size of the fault resistance. If the resistance is very low, a slightly higher frequency (e.g. 8KHz) can be selected; if the resistance is large, a low frequency can be selected.
- Start from the near end of the cable, check if there is any pitch change. If there is no pitch change, the fault point is at the near end.
- Before the fault point, there is a change of strong and weak pitch. The maximum

value can usually be measured above the fault point. After the fault point, the signal drops to a stable and small amplitude.

- Since the cable path is clearly marked, just go at a normal pace, not at a slow pace.

For power cables, the pitch is generally between 1/3 meter and 1 meter.

- If the signal is interrupted or reduced to a stable value, it generally means that the fault point is below the last signal peak. But there are also other reasons for the above results: (1) Increased depth; (2) There is an unrecorded branch, the fault point is on the branch, and the operator continues along the main cable; (3) joints. In all cases the operator should not hesitate to move forward, keeping in mind roughly the location of the last signal peak. It is easy to distinguish the joint, and the signal will resume immediately after a short drop. If the buried depth of the cable increases, it will continue to receive the signal of pitch change, there is no need to be too concerned.

- This is the only way to pinpoint a short circuit fault on a low-voltage, multiplex, loaded cable.

- Because the pitch is too small, this method is not suitable for communication and control cables, except when cables can be touched.

2. Fixed point of relative armor failure

1) Signal transmission method

For the low resistance fault of cable grounding relative to metal sheathed (armored), a disguised phase indirect method should be used. As shown in the figure below, the grounding of both ends of the armored cable should be unwound first, and the grounding of the zero line and ground line of the low-voltage cable should also be unwound. The output of the signal generator should be connected between a sound phase line and the armored, and the faulty phase and good phase of the connected signal should be short-circuited at the opposite end of the cable. The receiver must move parallel to the cable.

Relative armored ground fault point

2) Fixed-point method

Relative armoured low resistance grounding fault of fixed point method and the alternate with basically the same, but note that: before disabled points, the signal amplitude stable but is very small, after the point of failure, a nodal distance changes, fault point located above the first peak.

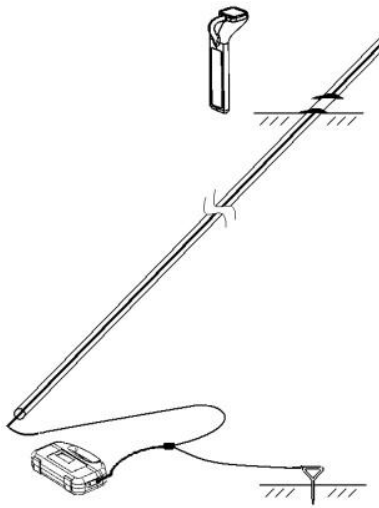

3. Point of wire breaking fault

1) Signal transmission method

For a broken line fault, the output of the transmitter is connected between the fault phase and the ground, and the end is not treated.

The signal from the transmitter flows through the fault phase, and the interrupt at the breakdown point will not propagate forward.

For a pure line-break fault, before the fault point, the electricity flows through the distributed capacitance between the fault phase and the earth to the earth and returns to the transmitter.

For most unarmored low-voltage cables, the wire breaking fault is generally combined with ground, and the current flows to the earth mainly through the fault point and returns to the transmitter, as shown in the figure below:

Faulty wiring

2) Fixed-point method

The point of a broken line is basically the same as the normal line tracking.

Keep the receiver perpendicular to the cable, using the peak method, starting near the transmitter and gradually moving the probe to the far end.

The signal is strong before the fault point, and then weakens rapidly.

The point at which the signal begins to weaken is the point of failure.

The signal has no pitch change before and after the fault point, as shown in the figure below:

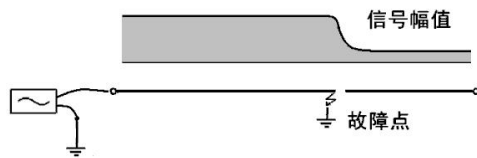

Break point

3) Matters needing attention:

This method is especially suitable for the breakdown point of unarmored low-voltage cable.

For armored cables, the current will be coupled to the armored cable through distributed capacitance, resulting in a full-length signal that cannot be distinguished between before and after faults.

It is recommended to use lower frequencies (e.g. 512Hz, 1KHz) for broken wires combined with ground faults, and higher frequencies (e.g. 8KHz) for pure broken wires.

According to the current value of the transmitter, if the current is large at low frequencies, then use low frequencies.

If the current is low, switch to high frequency.

For a pure break fault, with the increase of distance, the signal will decrease continuously and disappear at the fault point.

If the grounding resistance is not very large, the signal weakening phenomenon is not obvious.

4. Fixed point for relative failure of unarmored cable

1) Signal transmission method

- Relative fault wiring of unarmored cables

- As shown in the figure above, the ground at both ends of the zero line and ground line of the low-voltage cable are all unwound, and the output of the transmitter is connected directly between the fault phase and the ground.
- The signal flows from the transmitter to the fault phase, flows to the ground at the fault point, and returns to the transmitter.
- 2) Fixed-point method
- Similar to the cable break fault point, the receiver is kept perpendicular to the cable, using the peak method, starting near the transmitter and gradually moving the detection to the far end.
- The signal is strong before the fault point and weak after the fault point.
- The point at which the signal begins to weaken is the point of failure.
- The signal has no pitch change before and after the fault point.
- 3) Matters needing attention:
- Whether induction method can be used to butt the fault point on the ground mainly depends on the size of the fault resistance. The larger the fault resistance is, the weaker the signal changes before and after the fault point are, so that it is impossible to distinguish.
- The lower the low frequency is, the more obvious the strength change before and after the fault point is, so it is recommended to use low frequency detection (such as 512Hz or 1KHz).
- For phase fault, step voltage method is the dominant method, and this method is the auxiliary method.
- Before stepping over the voltage barrier, path detection is usually carried out first.
- During the path tracking process, observe whether there is an obvious change in the amplitude of the signal. If there is, it will be taken as a suspect, and focus on the stepping voltage fixed point in this region.
- If no sudden change of signal is observed, then this method is not applicable and step voltage method should be used instead.